

# ARCHIMEDE



design Angelo Pinaffo

Contenitore in acciaio a 6 moduli elettrici e/o multimediali.  
6 module steel box for electricity and/or multimedia system.  
Boîte en acier avec 6 éléments électriques et/ou multimédia.  
Container aus Stahl für 6 Strom-bzw. Multi-Media.

Barra di sbloccaggio meccanismi in tubo d'acciaio.  
Steel pipe bar used as release mechanism.  
Barre de déblocage mécanisme en tube d'acier.  
Querbalken aus stahlrohr zur betätigung des kippmechanismus.

Piano in Melaminico sp.25 mm, bordo in ABS 2 mm.  
Melamine top 25 mm thickness, edge in ABS 2 mm.  
Plateau mélaminé épaisseur 25 mm, chant en ABS 2 mm.  
Tischplatte Melamin 25 mm, mit Kante ABS 2 mm.



Sistema porta cavi orizzontale sottopiano in polipropilene.  
Under top system for horizontal cable running.  
Système de câblage horizontal sous plateau en.  
Halterungssystem für die Befestigung von Kabeln unterhalb der Tischplatte.

Passacavi verticale in acciaio ad incastro.  
Vertical cable management system in steel for legs.  
Goulotte passage câbles verticale pour montant en acier.  
Vertikaler Kabelkanal aus Stahl für die Tischbeine.

Gancio in nylon grigio per unione piani.  
Grey linking device in nylon to join table tops.  
Crochet en nylon gris pour jonction plateaux.  
Grauer Tischplattenverbinder.

Montante in tubo d'acciaio a sezione ovale con estremità conificata.  
Oval steel pipe column with conical end.  
Montant de pied en forme de cône à l'extrémité en tube d'acier.  
Standfuß aus ovalem Stahlrohr mit konischem Ende.



Finiture piani / Top Finishes / Finition plateaux / Ausführungen Tischplatte



Acero HOF  
Erable HOF  
Maple HOF  
Ahorn HOF

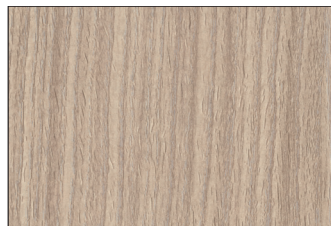

Rovere chiaro OON  
Light oak OON  
Chêne clair OON  
Eiche hell OON

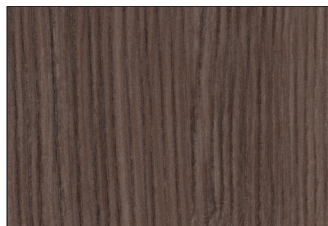

Noce 3844  
Walnut 3844  
Noyer 3844  
Walnuss 3844

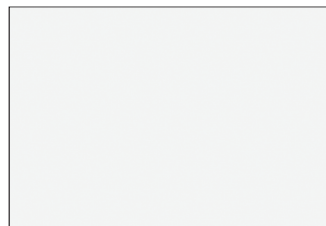

Bianco U12  
White U12  
Blanc U12  
Weiß U12

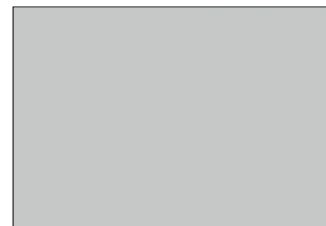

Grigio OFF  
Grey OFF  
Gris OFF  
Grau OFF

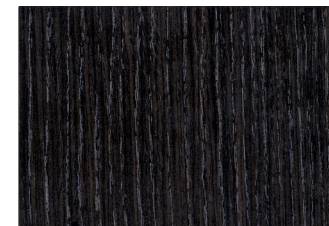

Wengé OF4  
Wenge OF4  
Wengé OF4  
Wenge OF4

Finiture gambe / Legs Finishes / Finition piétements / Ausführungen Untergestell

• 50 cm •

• 60 cm •

• 80 cm •



Bianco/White/Blanc/Weiß



Cromata-Nera/Chromed-Black  
Chromée-Noire/Verchromt-Schwarz



Grigio/Grey/Gris/Grau

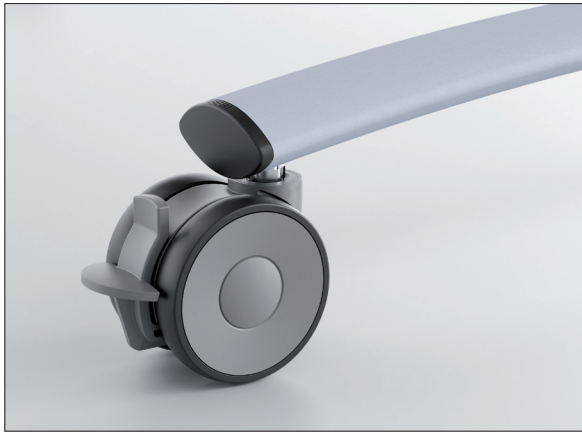

Ruota girevole con freno (kick pedal)  $\varnothing$  75 mm.  
Supporto in polipropilene con battistrada in gomma termoplastica, adatta per pavimenti moquette.  
Portata statica 120 kg.

Swivel castor with kick pedal brake  $\varnothing$  75 mm.  
Polypropylene support with thermoplastic rubber tread. Suitable for carpet floors. Load capacity (static) 120 kg.

Roulette pivotante avec frein (kick pedal)  $\varnothing$  75 mm.  
Corps en polypropylène avec bandage en caoutchouc thermoplastique.

Drehbare Lenkrollen mit Feststellbremse  $\varnothing$  75 mm.  
Gehäuse aus Polypropylen, Lauffläche aus thermoplastischem Gummi. Für Teppichboden geeignet.  
Belastbarkeit (statisch) bis 120 kg.

Perno ruota avvitato al dado posto all'interno del porta-ruota in nylon, per garantire resistenza nel tempo.

Pin castor is screwed to the nut placed internally of the nylon castor holder to guarantee lasting resistance.

Pivot roue vissé à l'écrou dans le bouchon en nylon afin de garantir la résistance dans le temps.

Die Lenkrollen werden an dem Verbindungsstück aus Nylon festgeschraubt, um dauerhafte Stabilität zu gewährleisten.

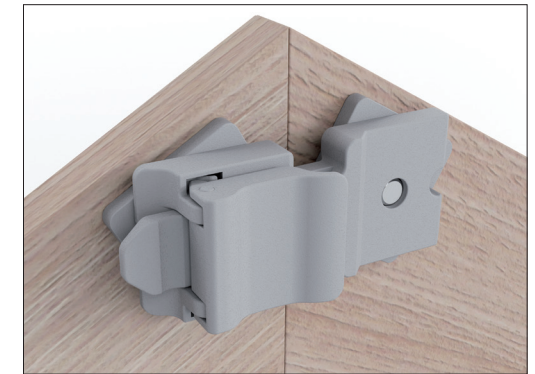
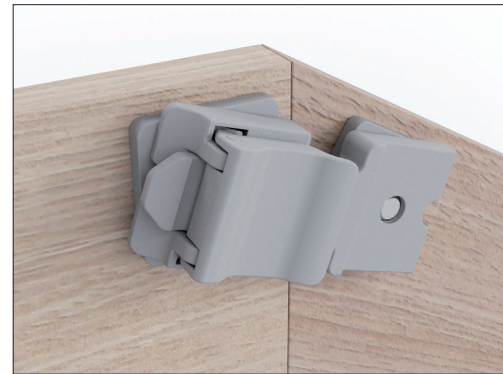
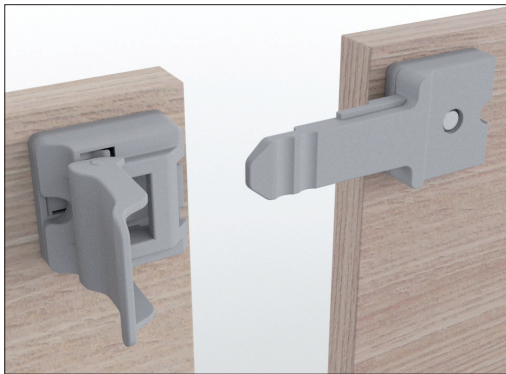
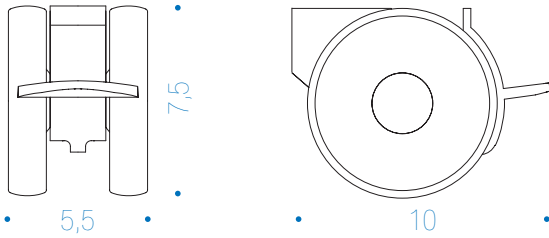

Gancio in nylon grigio per unione piani con angoli da 60°, 90° e 120°.

Grey linking device in nylon to join 60°, 90° and 120° corner table tops.

Crochet en nylon gris pour jonction plateaux avec angles de 60°, 90° et 120°.

Grauer Tischplattenverbinder um Tischplattenecken mit einem Winkel von 60°, 90° bzw. 120° zusammenzufügen.

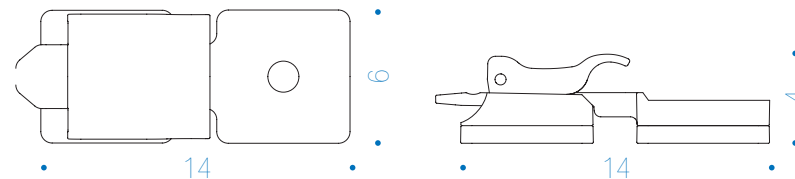

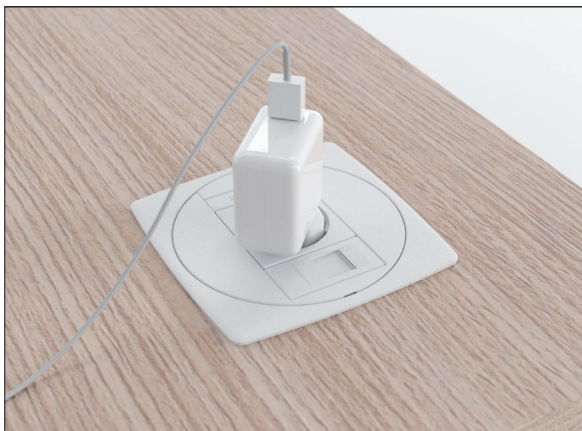

Modulo singolo in ABS con sistema elettrico e/o multimediale.

Single module in ABS for electricity and/or multimedia system.

Point de connexion multifonction électrique et/ou multimédia en ABS.

Strom-bzw. Multi-Media-Anschluss aus ABS.

### KIT06\*

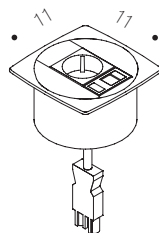

### KIT03

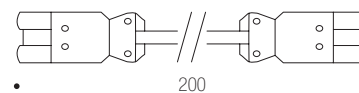

Cavo di connessione tra moduli elettrici 2 mt (H05VV-F 3G 1.5 mm<sup>2</sup> / GST18 - GST18)

Connection cable to joint variable plug power supply system 2 mt (H05VV-F 3G 1.5 mm<sup>2</sup> / GST18 - GST18)

Câble de connexion entre multi-prise électrique 2 mt (H05VV-F 3G 1.5 mm<sup>2</sup> / GST18 - GST18)

Verbindungskabel für Steckdosenmodul 2 mt (H05VV-F 3G 1.5 mm<sup>2</sup> / GST18 - GST18)

### KIT09

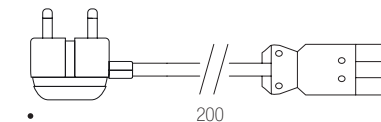

Cavo elettrico 2 mt (H05VV-F 3G 1.5 mm<sup>2</sup> / GST18 – Spina Maschio)

Electric cable 2 mt (H05VV-F 3G 1.5 mm<sup>2</sup> / GST18 – Male Socket)

Câble électrique 2 mt (H05VV-F 3G 1.5 mm<sup>2</sup> / GST18 – Prise Mâle)

Elektrokabel 2 mt (H05VV-F 3G 1.5 mm<sup>2</sup> / GST18 – Stecker männlich)

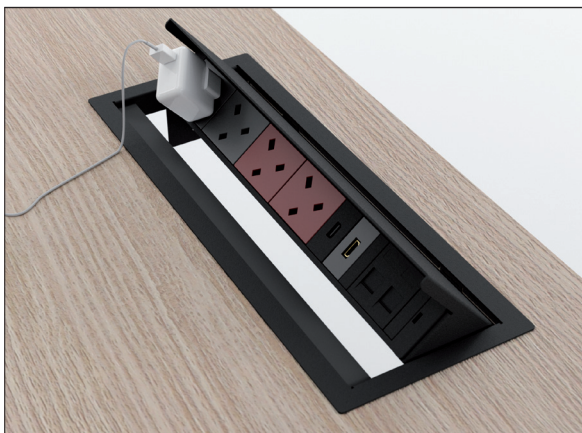

Contenitore in acciaio a 4 o 6 moduli elettrici e/o multimediali.

4 or 6 module steel box for electricity and/or multimedia system.

Boîte en acier avec 4 ou 6 éléments électriques et/ou multimédia.

Container aus Stahl für 4 oder 6 Strom-bzw. Multi-Media Module.

### KIT07\*

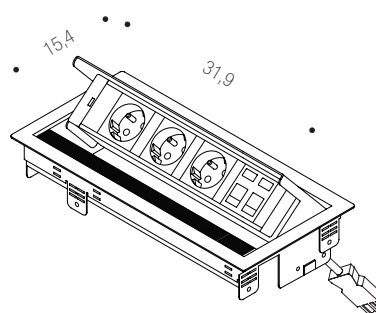

### KIT08\*

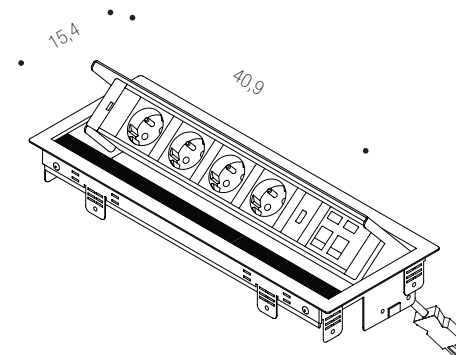

\* PRESE ELETTRICHE INTERNAZIONALI / \*INTERNATIONAL SOCKETS  
 \* PRISES ÉLECTRIQUES INTERNATIONALES / \*INTERNATIONALE STECKDOSEN



Suko



French



Italian



Danish



Swiss



British



American



Euro-American



VGA

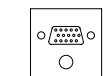

VGA+Stereo



Stereo



USB 2.0



HDMI



RJ45

\* ACCESSORI MULTIMEDIALI / \*MULTIMEDIA ACCESSORIES  
 \* ACCESSOIRES MULTIMÉDIAS / \*MULTIMEDIA-ZUBEHÖR

Forme e misure piani / Shapes and dimensions of the tops / Formes et dimensions plateaux / Abmessungen Tischplatte

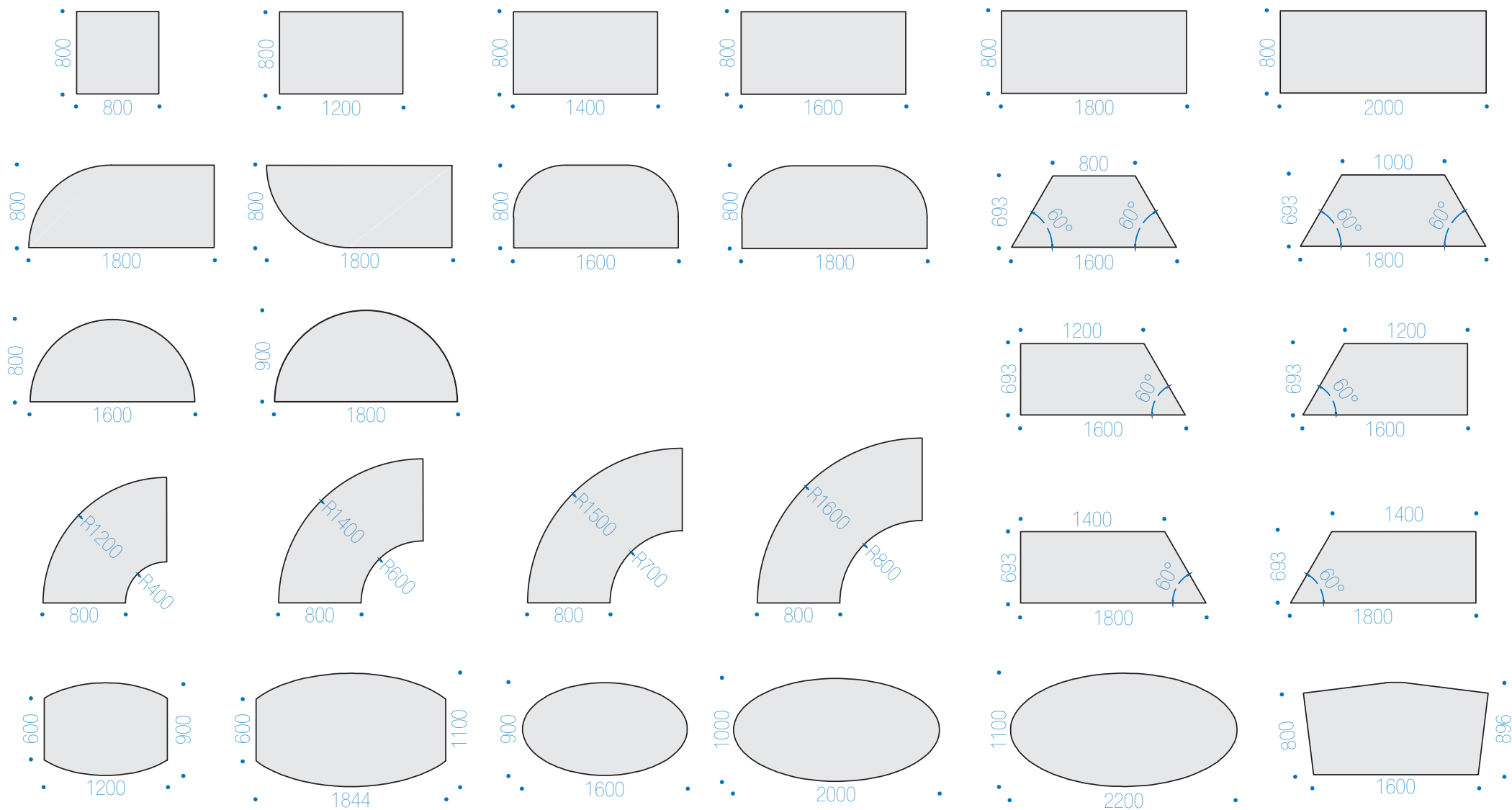

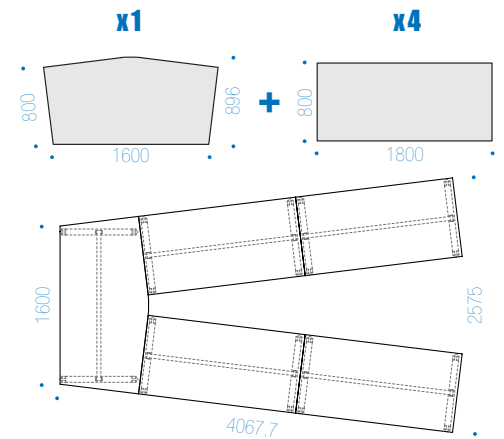
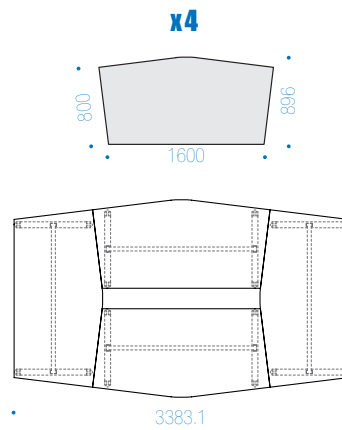
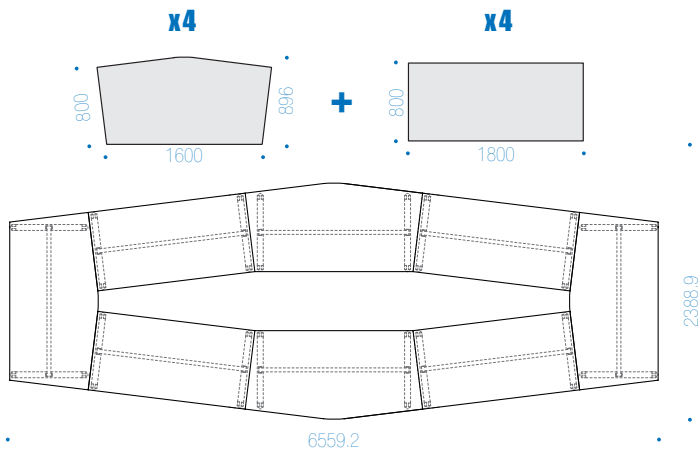
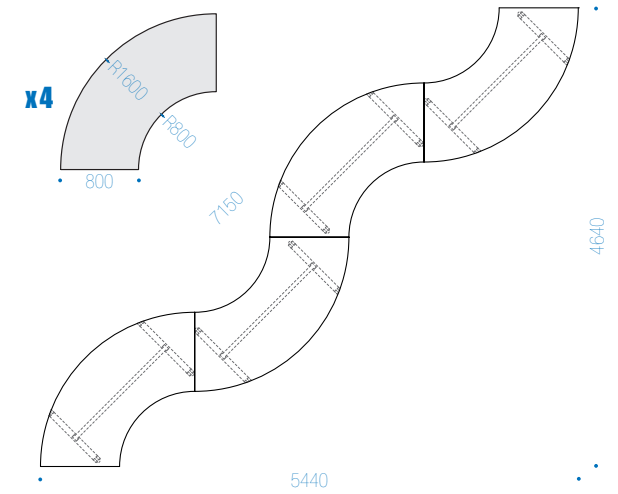
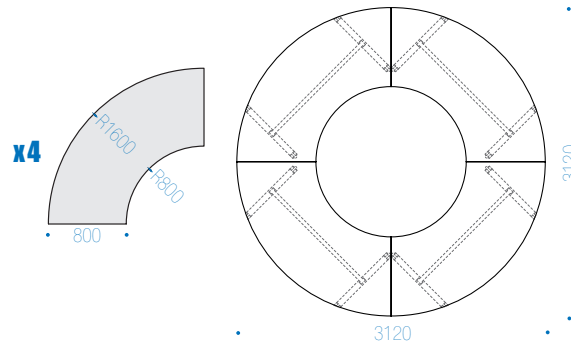
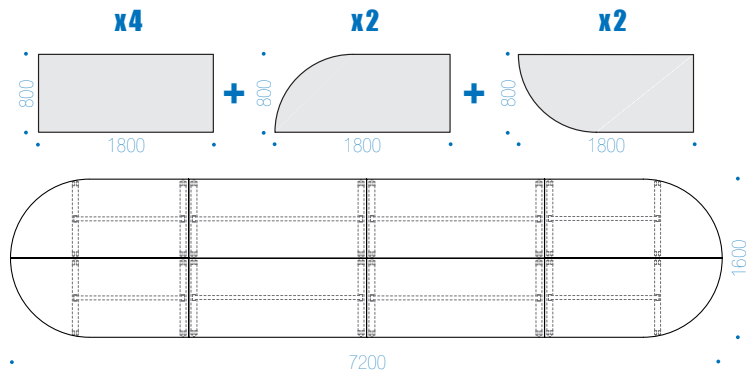
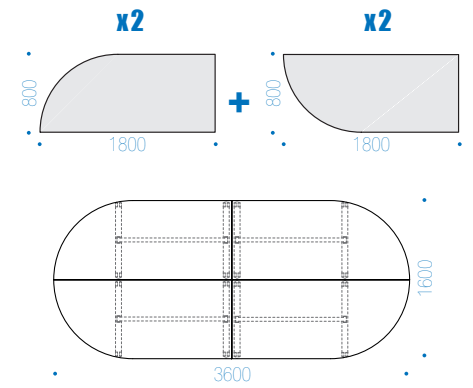
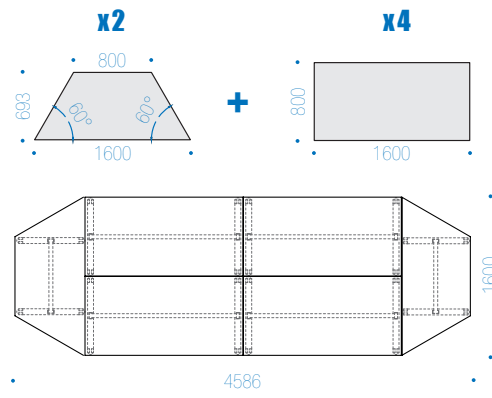
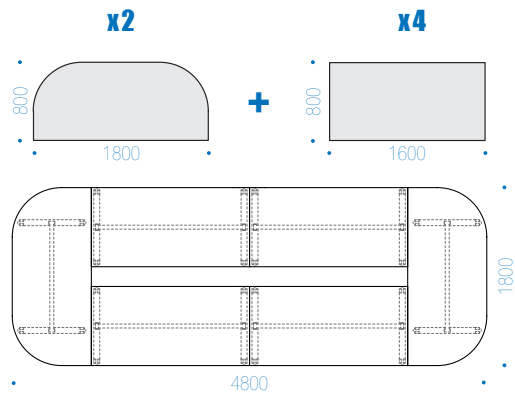

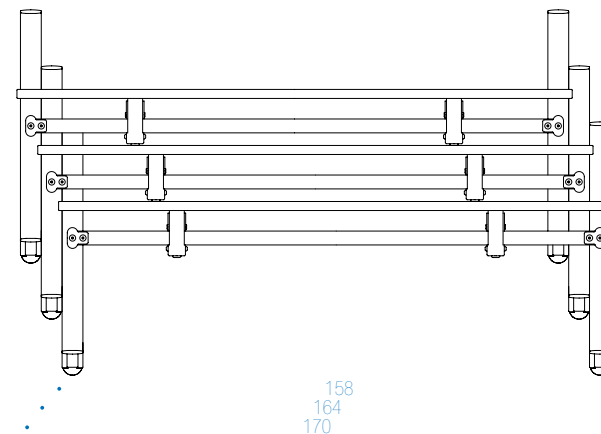
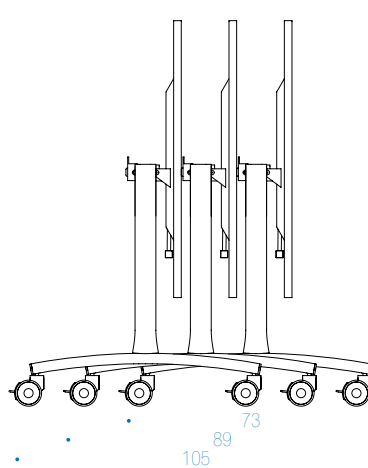
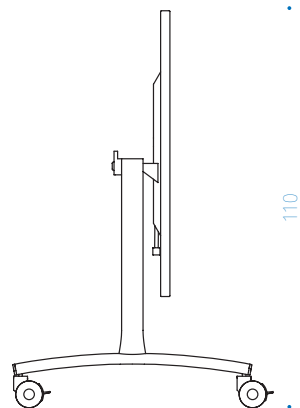
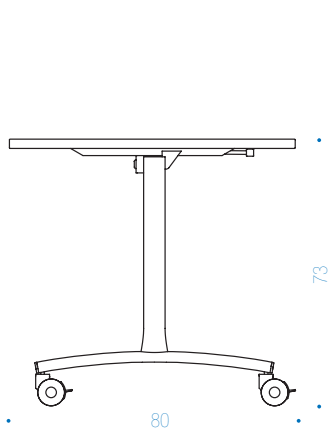
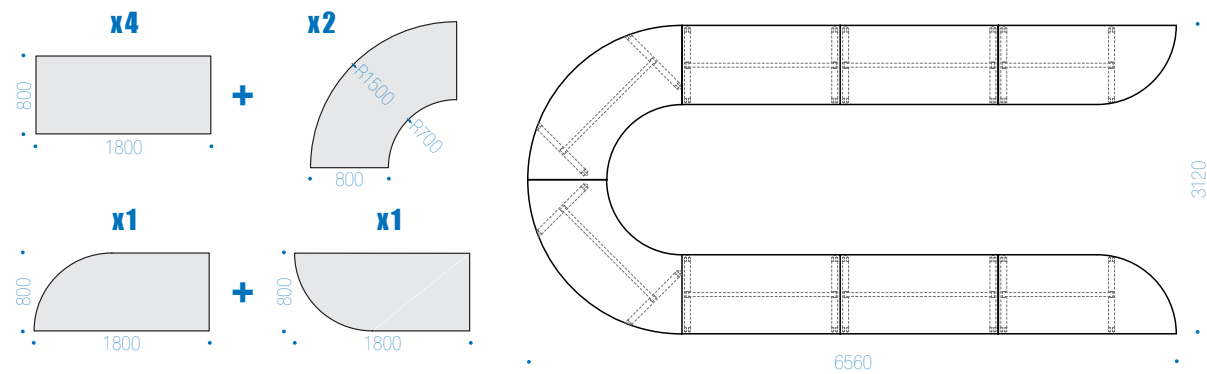
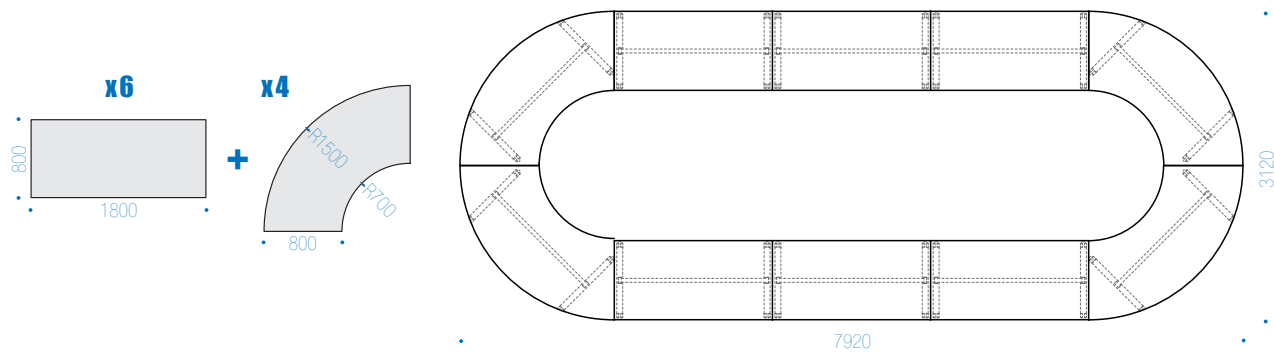
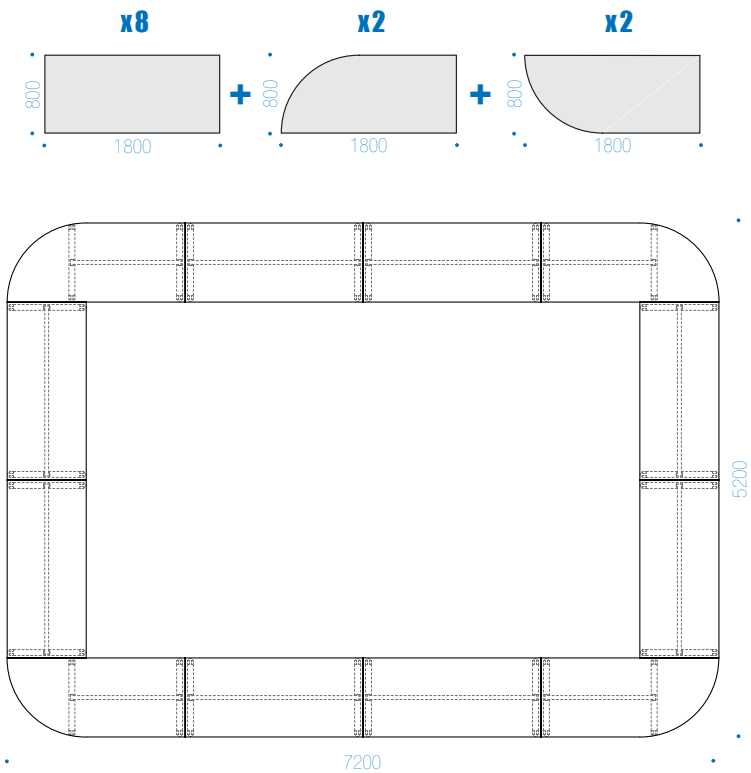

## Pulizia / Cleaning / Entretien / Reinigung

Per le parti metalliche consigliamo esclusivamente un panno morbido e alcool asciugando bene dopo la pulizia. Per le superfici laccate, usare panno umido ed acqua con detersivo liquido neutro, non usare solventi, trielina, acetone o ammoniaca.

For the metal parts, we recommend to only use a damp cloth with alcohol and to dry all very well after cleaning. For the lacquered top, use a damp cloth with neutral liquid detergent. Do not use solvents, trichloroethylene, acetone or ammonia.

Pour les parties métalliques, nous recommandons exclusivement un tissu doux et un alcool séchant bien après le nettoyage. Pour le plan vernis, il faut utiliser un tissu humide et un détergent neutre, ne pas utiliser de solvants, trichloréthylène, acétone ou ammoniaque.

Für Metallteile, empfehlen wir nur ein feuchtes Tuch mit Alkohol zu verwenden und nach jeder Reinigung alles gut abzutrocknen. Für lackierte Tischplatten ein feuchtes Tuch mit neutralem Flüssigreiniger verwenden. Keine Lösungsmittel, Trichlorethylen, Aceton oder Ammoniak verwenden.

## Garanzia / Guaranteed / Certificat / Konformitätszertifikat

I nostri prodotti sono garantiti 10 anni.  
(testo integrale della garanzia su richiesta).

Our products are guaranteed for 10 years.  
(detailed guarantee document available upon request).

Nos produits sont garantis 10 ans.  
(sur demande, texte intégral de la garantie).

Unsere Produkte haben eine Garantie von 10 Jahren.  
(detaillierte Garantieunterlagen sind auf Anfrage erhältlich).

# CATAS®

Archimede ha superato i test di prova secondo UNI EN 1728:2008 livello 3° severo (ospedali, case per anziani, caserme, stazioni di polizia, spogliatoi sportivi, locali pubblici, aeroporti, ecc.).

Hoht has passed tests according to the standard BS EN 1728:2008 level 3 severe (hospitals, home for the aged, barracks, police stations, hanging rooms, public places, airports, etc.).

Hoht a dépasse les tests NF EN 1728:2008 niveau 3 sévère (hôpitaux, pensionnats pour les anciens, casernes, gendarmeries, vestiaires, endroits publics, aéroports, etc.).

Hoht hat mit Erfolg die Prüfung Tests für UNI EN 1728:2008 bestanden, Stufe 3° starke Beanspruchung (Krankenhäuser, Altenheimen, Kaserne und Polizeistationen, Sportlich Umkleideraum, Allgemeine Fläche, Flughäfen, usw.).



Via A. Manzoni, 27 30025 Fossalta di Portogruaro (Venezia) - Italy  
T. +39 0421.244.264 - F. +39 0421.170.208.0  
info@ibebi.com - ibebi.com